

27 JUNE 1979

SPRAY OUTFIT, PAINT, MODEL 50-6609 ENGINE, GASOLINE, 3 HP STANDARD, MODEL 2A016-3

Reference: TM5-4940-228-14, C9100-IL, TM5-2805-257-14

Intervals and related task-hour times are based on normal hours of operation. The task-hour time specified is the time you need to do all the services prescribed for a particular interval. Change the interval if your lubricants are contaminated or if you are operating the equipment under adverse operating conditions, including longer-than-usual operating hours. You may extend the interval during periods of low activity, but you must take adequate preservation precautions.

*The time specified is the time required to perform all services at the particular interval.

Clean fittings before lubricating. Relubricate all areas exposed to water after amphibious operation. Lubricate points

indicated by dotted arrow shaft on both sides of equipment. Clean parts with SOLVENT, dry cleaning, or with OIL, fuel, diesel. Dry before lubricating. Drain crankcase when HOT. Fill and check level. The lowest level of maintenance authorized to lubricate a point is indicated by one of the following (C) Operator/crew; or (O) Organizational Maintenance.

You can help improve this publication. If you find any mistakes or if you know of a way to improve the procedures, please let us know. Your letter or DA Form 2028 (Recommended Changes to Publications and Blank Forms) should be mailed directly to: Commander, U. S. Army Troop Support & Aviation Materiel Readiness Command, ATTN: DRSTS-MTPS, 4300 Goodfellow Blvd. St. Louis, MO 63120. A reply will be furnished to you.

LUBRICANT • INTERVAL

INTERVAL • LUBRICANT

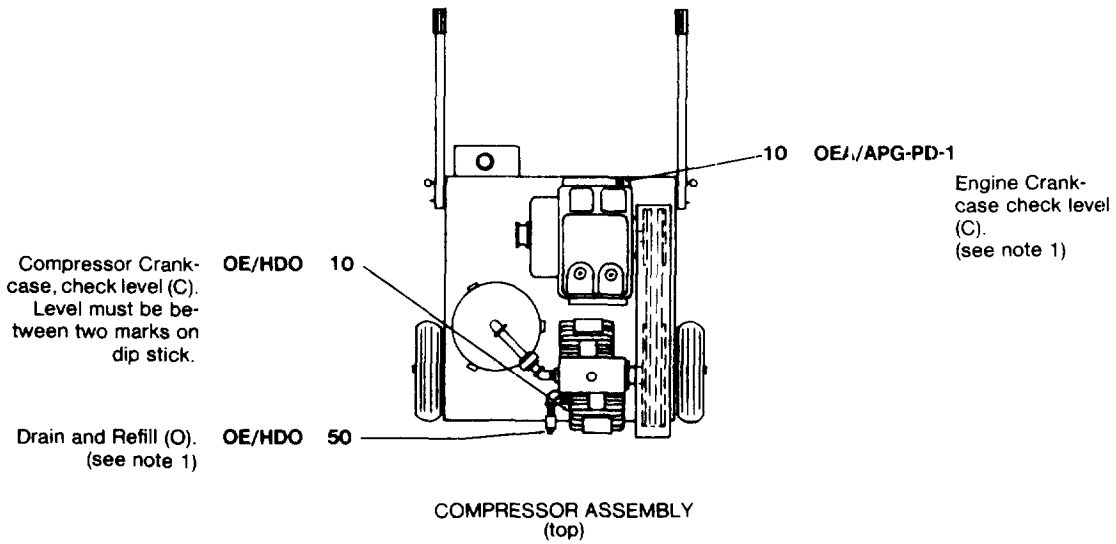

TOTAL	TASK-HOUR
INTERVAL	TASK-HOUR
10	0.2
30	0.4
50	0.6

LUBRICANT	REFILL CAPACITY (APP)	EXPECTED TEMPERATURES			INTERVAL
		Above +32°F (0°C)	+40°F to -10°F (4.4°C to -23°C)	0°F to -65°F (-18°C to -54°C)	
OE HDO (MIL-L-2104C) - Lubricating oil internal combustion engine heavy duty or OEA/APG-PD-1 - Compressor crankcase - Engine crankcase	1 qt. (.946 l) 4/5 qt. (.757 l)	OEA/APG-PD-1 30	OEA/APG-PD-1 10	CES	Intervals given are in hours of normal operation.
GAA (MIL-G-10924C(1)) Grease, automotive and artillery wheel bearings	as req.	All Temperatures			

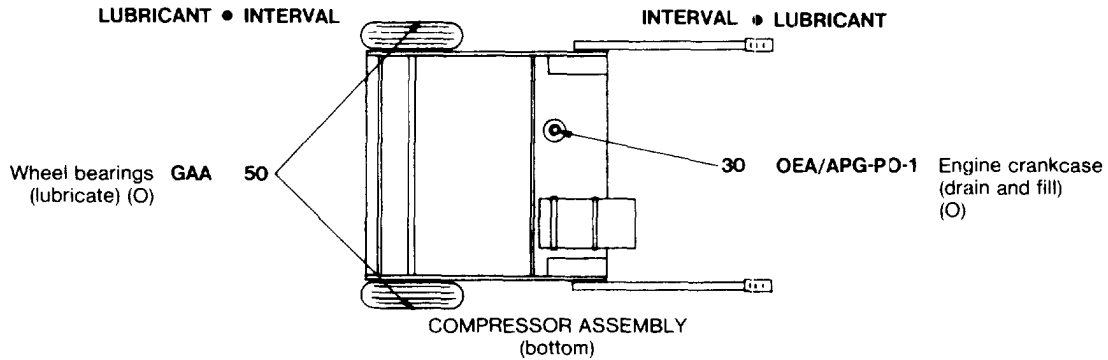

NOTES:

1. FOR OPERATION OF EQUIPMENT IN PROTRACTED COLD TEMPERATURES BELOW -10°F (-23°C). Remove lubricants prescribed in the key for temperatures above -10°F (-23°C). Clean parts with SOLVENT, dry-cleaning. Relubricate with lubricants specified in the key for temperatures below -10°F (-23°C).

2. Copy of this Lubrication Order will remain with the equipment at all times; instructions contained herein are mandatory.

BY ORDER OF THE SECRETARY OF THE ARMY:
BERNARD W. ROGERS
 General, United States Army
 Chief of Staff

OFFICIAL:
J. C. PENNINGTON
 Major General, United States Army
 The Adjutant General

DISTRIBUTION: To be distributed in accordance with DA Form 12-25A, Operator Maintenance requirements for Petroleum Distribution.

RECOMMENDED CHANGES TO EQUIPMENT TECHNICAL PUBLICATIONS



THEN...JOT DOWN THE DOPE ABOUT IT ON THIS FORM. CAREFULLY TEAR IT OUT, FOLD IT AND DROP IT IN THE MAIL.

SOMETHING WRONG WITH PUBLICATION

FROM: (PRINT YOUR UNIT'S COMPLETE ADDRESS)

DATE SENT

PUBLICATION NUMBER

PUBLICATION DATE

PUBLICATION TITLE

BE EXACT PIN-POINT WHERE IT IS

PAGE NO.

PARA-GRAPH

FIGURE NO.

TABLE NO.

IN THIS SPACE, TELL WHAT IS WRONG AND WHAT SHOULD BE DONE ABOUT IT.

TEAR ALONG PERFORATED LINE

PRINTED NAME, GRADE OR TITLE AND TELEPHONE NUMBER

SIGN HERE

THE METRIC SYSTEM AND EQUIVALENTS

WEIGHT MEASURE

1 Centimeter = 10 Millimeters = 0.01 Meters = 0.3937 Inches
 1 Meter = 100 Centimeters = 1000 Millimeters = 39.37 Inches
 1 Kilometer = 1000 Meters = 0.621 Miles

WEIGHTS

1 Gram = 0.001 Kilograms = 1000 Milligrams = 0.035 Ounces
 1 Kilogram = 1000 Grams = 2.2 lb.
 1 Metric Ton = 1000 Kilograms = 1 Megagram = 1.1 Short Tons

LIQUID MEASURE

1 Milliliter = 0.001 Liters = 0.0338 Fluid Ounces
 1 Liter = 1000 Milliliters = 33.82 Fluid Ounces

SQUARE MEASURE

1 Sq. Centimeter = 100 Sq. Millimeters = 0.155 Sq. Inches
 1 Sq. Meter = 10,000 Sq. Centimeters = 10.76 Sq. Feet
 1 Sq. Kilometer = 1,000,000 Sq. Meters = 0.386 Sq. Miles

CUBIC MEASURE

1 Cu. Centimeter = 1000 Cu. Millimeters = 0.06 Cu. Inches
 1 Cu. Meter = 1,000,000 Cu. Centimeters = 35.31 Cu. Feet

TEMPERATURE

$5/9(^{\circ}\text{F} - 32) = ^{\circ}\text{C}$
 212° Fahrenheit is equivalent to 100° Celsius
 90° Fahrenheit is equivalent to 32.2° Celsius
 32° Fahrenheit is equivalent to 0° Celsius
 $9/5^{\circ}\text{C} + 32 = ^{\circ}\text{F}$

APPROXIMATE CONVERSION FACTORS

TO CHANGE	TO	MULTIPLY BY
Inches	Centimeters	2.540
Feet	Meters	0.305
Yards	Meters	0.914
Miles	Kilometers	1.609
Square Inches	Square Centimeters	6.451
Square Feet	Square Meters	0.093
Square Yards	Square Meters	0.836
Square Miles	Square Kilometers	2.590
Acres	Square Hectometers	0.405
Cubic Feet	Cubic Meters	0.028
Cubic Yards	Cubic Meters	0.765
Fluid Ounces	Milliliters	29.573
its	Liters	0.473
arts	Liters	0.946
allons	Liters	3.785
Ounces	Grams	28.349
Pounds	Kilograms	0.454
Short Tons	Metric Tons	0.907
Pound-Feet	Newton-Meters	1.356
Pounds per Square Inch	Kilopascals	6.895
Miles per Gallon	Kilometers per Liter	0.425
Miles per Hour	Kilometers per Hour	1.609

TO CHANGE	TO	MULTIPLY BY
Centimeters	Inches	0.394
Meters	Feet	3.280
Meters	Yards	1.094
Kilometers	Miles	0.621
Square Centimeters	Square Inches	0.155
Square Meters	Square Feet	10.764
Square Meters	Square Yards	1.196
Square Kilometers	Square Miles	0.386
Square Hectometers	Acres	2.471
Cubic Meters	Cubic Feet	35.315
Cubic Meters	Cubic Yards	1.308
Milliliters	Fluid Ounces	0.034
Liters	Pints	2.113
Liters	Quarts	1.057
ers	Gallons	0.264
ms	Ounces	0.035
ograms	Pounds	2.205
Metric Tons	Short Tons	1.102
Newton-Meters	Pounds-Feet	0.738
Kilopascals	Pounds per Square Inch	0.145
ometers per Liter	Miles per Gallon	2.354
ometers per Hour	Miles per Hour	0.621

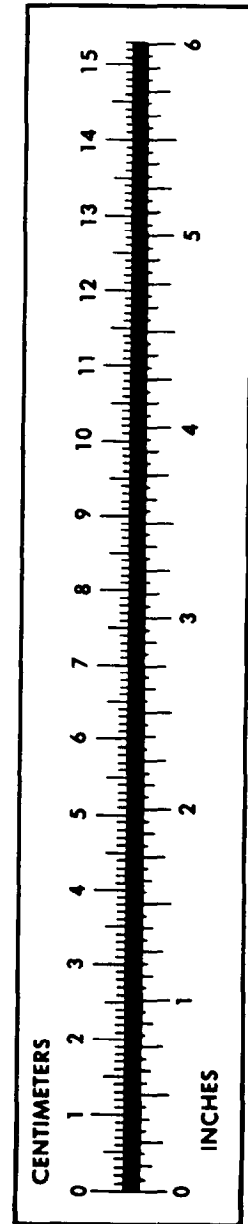

PIN: 042356-000